



**FEEL**

Virtue Suspension Manual

## Contents:

1. Introduction
2. Equilink Function Simply Explained
3. Setup
4. Rebuild / Maintenance
5. Parts Lists
6. Carbon Care Guide

### 1. Introduction To The Equilink:

Congratulations on purchasing this high quality Felt Equilink equipped bicycle. As with all of our bikes and components, our aim is to provide you, the rider, with the best possible product and therefore the best possible riding experience.

Please read this Equilink owners manual supplement thoroughly, as its purpose is to help you better understand your bike, set it up correctly, and care for it. If there are any questions that you still have after reading this guide, please contact your Felt Equilink Authorized Dealer, or visit our comprehensive Equilink website at [www.Feltbicycles.com](http://www.Feltbicycles.com).

Happy Trails!  
Felt Bicycles.

### 2. The Equilink Function Simply Explained:

In this illustration notice the red **Equilink** located behind the seat tube. The positioning of this special link counteracts weight transfer, so that the drivetrain doesn't have to.

As you pedal, the **Equilink** automatically pulls down on the upper horizontal link, which instantly negates and equalizes weight transfer. The harder you pedal the more weight transfer you initiate. The Equilink simply mirrors the effort, keeping a constant state of equalization. By allowing the drivetrain to do what it was meant to do (move you forward), we are able to maximize pedaling efficiency while allowing the suspension to remain equalized, and stay ultra-compliant as it moves freely over even the smallest of bumps.



### 3. Equilink Suspension Setup Guide:

Each Felt Suspension bike has a recommended shock absorber sag setting range that corresponds with the type of riding that model was designed for. This suggested setting can usually be found as a laser-etched mark or decal on either the left or right upper link plate close the top end of the shock absorber.

To determine your actual sag you must first slide the travel indicator on the shock absorber (the small "o"-ring on the effective shaft of the shock) upwards until it rests against the larger part of the shock. Be sure to turn off the "Pro Pedal" on bikes equipped with an RP23 shock. Then, with both hands on the respective handlebar grips throw a leg over the bike and gently allow your full body weight to compress the suspension. Then, slowly roll off lifting your weight off the bike. When you now look at the shock you will see that the o-ring has moved. The distance between the o-ring and the top body of the shock is the actual shock sag dimension.

**Important:** Try not to "bounce" or sit up while applying weight to the bike. Doing so can drastically throw off the resulting measurement. If you feel you have made an error, you can easily slide the travel indicator up and start over.

Suggested sag settings should only be used as an initial starting point. In many cases the actual settings that work best for you may be different than what works for others due to riding style, terrain or simply personal preference. Since the performance of the suspension is not dictated by certain shock settings or specific ride height, we suggest that you experiment with air pressure and damping settings to arrive at "your" desired feel. More sag (less air pressure) for a softer, suppler ride or less sag (more air pressure) for a firmer ride.

**WARNING:** The bicycle should be considered as a system when setting air pressures. Changing rear shock air pressure will effectively change the bikes geometry, so the fork air pressure/preload should be checked at the same time for correct sag to ensure proper geometry and handling. Failure to do so could adversely affect steering and handling characteristics, resulting in possible loss of control, injury, or even death. Refer to the fork owner's manual for instructions on setting correct sag, air pressure and damping settings. If you did not receive or misplaced your fork owner's manual, refer to the manufacturer's website for details on proper care and maintenance procedures.

## 4. Equilink Maintenance Overview:

### General Maintenance

All bearings used on Felt suspension frames are high quality sealed units. They are designed to provide a long working life; however keeping the bearings clean will extend their useful life.

When cleaning your bike, avoid the use of high pressure water or aerosol spray cleaners. Doing so will drive contaminants into the bearings, causing premature failure. The easiest and simplest way of cleaning the frame is using a bucket of soap and water. This will remove all exterior dirt and grime, preserving the integrity of the bearing seals.

When cleaning the frame it is good practice to periodically check for bearing wear.

1. With the bike in a workstand, clamped by the seatpost, remove the rear wheel and deflate the rear shock.
2. Standing behind the frame, lift the rear dropouts, (Move suspension as shown in Fig.1) it should feel smooth, (with light resistance from the carbon rear triangle on so equipped bikes). Any grinding, notchiness or tight spots may be signs that the bearings need to be overhauled.

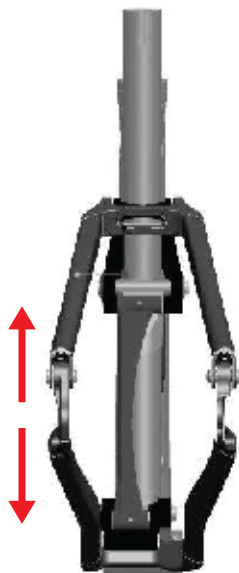

Fig.1

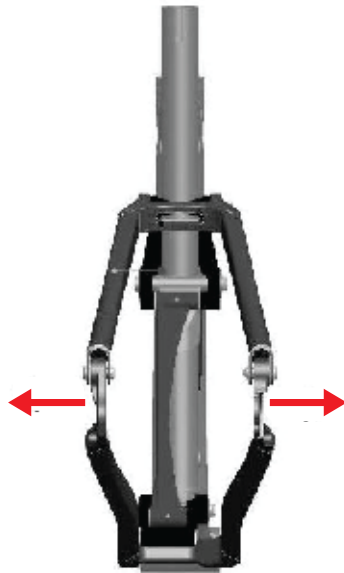

Fig.2

3. If the suspension moves smoothly through its travel, check for any side to side movement. Hold the dropouts and try and move them to the left and right. Any looseness may be a sign of loose bearing bolts or worn bearings. (Move suspension as shown in Fig.2)
4. Check the bearing bolts, if any are loose tighten them to the torque spec that is conveniently laser etched into the dust shields. In some instances it may be necessary to reapply a thread locker before you retighten the bearing bolts.
5. If you notice any wear or problems with the bearings your easiest course of action is to replace them. Bearing replacement kits are reasonably inexpensive (remember we use commonly sized bearings for that very reason) and the procedure is fairly simple. Bearing kits and complete rebuild kits are available through your local Felt Bicycles retailer.
6. For rear shock maintenance refer to the shock manufacturers owners manual that was included with your bike. If you did not receive or misplaced your shock owner's manual, refer to the manufacturer's website for details on proper care and maintenance procedures.

## Bearing Replacement:

**IMPORTANT** - Read and thoroughly comprehend these instructions prior to beginning. Doing so will save you time in the long run and help keep your Felt frame running smoothly and safely.

Tools required:

Loctite 242 (Thread Locken)  
4mm, 5mm and 6mm Allen (hex) wrench  
Torque wrench (Metric) with 5 and 6mm hex bit  
12mm and 15mm open wrench  
Equilink Bearing removal/installation tool kit  
Rubber/plastic faced hammer  
X-acto knife or dental pick  
Cleaner/degreaser  
Acetone or similar solvent  
G-Tip or similar  
Good Quality Pliers

Frame Disassembly:

1. **CLEAN YOUR BIKE!!** Even if you clean your bike regularly, clean it again. Dirt and contaminants including oil and grease will affect the reassembly of the frame components and could prevent bearings from seating correctly and could also keep the Loctite from curing.
2. After clamping the bike in a work stand, remove the wheels, rear derailleur, rear brake caliper, crank set and BB. The fewer components on the frame the easier it will be for you to work on!
3. Break loose each pivot bolt, but do not remove any hardware yet.
4. Deflate the shock, remove the shock mounting bolts and set the shock to the side.
5. Remove the Equilink mounting bolts and axles, and remove the Equilink from the upper and lower links. Set the Equilink to one side with the shock.
6. Remove the upper and lower bearing bolt/dust shield assemblies that attach the rear triangle to the linkage. Remove the rear triangle along with the stainless steel spacer washers that are in between the bearings and the linkage components.
7. Now remove the bearing bolt/dust shield assembly from the lower link. The lower link should be free from the frame. Be careful to not lose any stainless steel spacer washers.
8. Remove the bearing bolt/dust shield assembly from the shock links. Be careful to catch the link spacer (item #6 in Fig. 12) at the back of the link and the stainless steel spacer washers. The shock link plates should now be free from the frame.

## Master Bearing Tool Kit Diagram:

**Note:** Not all tools from the master tool kit will be needed for this model of Felt Bicycle and may not be included in your bike's tool kit.

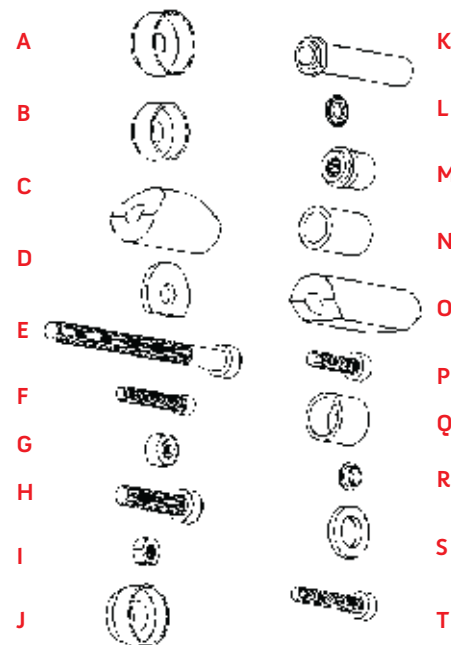

## Removing Bearings:

1. Place the links flat on your bench and assemble the bearing removal tools as shown in fig. 3. Use an Allen wrench and open wrench to draw the bearings out of the links. Repeat this process for the lower link bearings, chain stay yoke bearings and seat stay bearings (Use tool "B" in place of tool "A" for the smaller Seat Stay Yoke bearings) as needed.

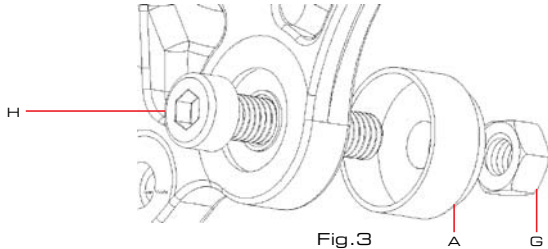

Fig.3

2. Disassemble The dropout Pivots as follows: (Bikes with aluminum rear triangles only)

A Remove the Chain stays from the seat stays by removing the Dropout Axle Bolt at each dropout and then removing the Dropout Axle.

B Orient the tools as seen in Fig. 4.

C As you tighten the bolt the DU Press (M) pushes the DU Bushing into the DU Receiver (Q). Repeat for both Left and Right dropouts.

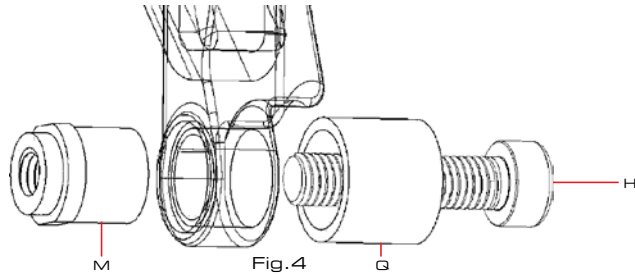

Fig.4

3. To remove the Equilink DU Bushings you must first remove the Grease Needle Fittings. This can be done by gently pulling them out with a set of good quality pliers. Discard the fittings you just removed. There is a new set of grease fittings included with your rebuild kit. After the grease fittings are removed, orient the tools as shown in Fig. 5. Tighten the bolt until both DUs inside each (top and bottom) barrel of the Equilink are pressed into the DU Receiver (N).

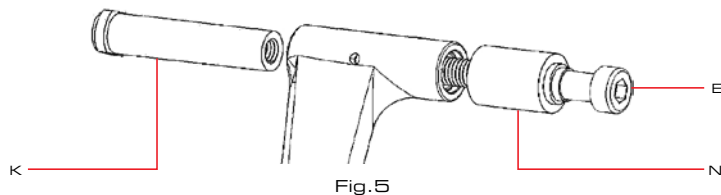

Fig.5

## Installing Bearings:

1. Once all the bearings have been removed, clean the bearing bores using the dental pick or X-acto knife to remove all traces of old bearing seating compound/green loctite. Wipe down the bearing bore with a Q-tip soaked in a small amount of solvent such as acetone. This will remove any last traces of loctite and other contaminants. Don't get solvent on any other portion of the frame or rear triangle as damage to the paint or carbon resin may occur.

**IMPORTANT** - The properties that make Acetone and similar solvents work so well as a cleaner can also harm paint and break down carbon fiber resin. Be very careful where you apply the solvent as it may compromise the integrity of the rear triangle and/or the paint finish of your frame.

(Caution-Eye and Hand protection should **ALWAYS** be used when handling solvents to avoid contact!)

2. Once you've cleaned the bearing bores, apply a small amount of grease to the inside surface of the bearing bore and the outside of the bearing. Assemble the bearing installation tool (as shown in Fig.6). Using the Allen wrench and open wrench to press (or draw) the bearing into place. Make sure the bearing is seated completely and cleanly into the link. Repeat this process for the Seat Stay Yoke bearings (Use tool "B" in place of tool "A" for the smaller Seat Stay Yoke bearings) as needed.

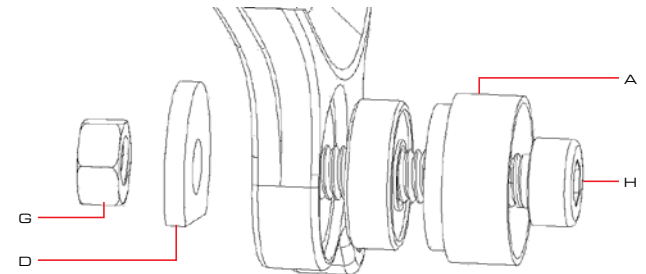

Fig.6

3. To reassemble the lower link you will use the link support included in the Equilink tool kit. Install the bearings one at a time as shown in Fig. 7.

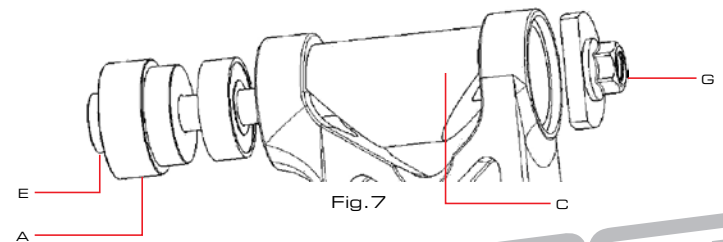
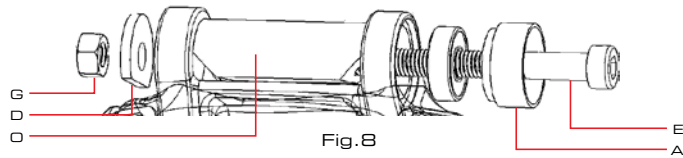
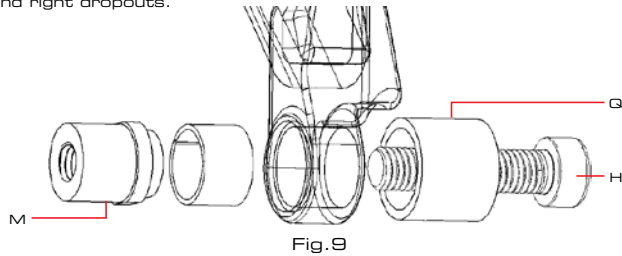

Fig.7

- To press new the bearings into the Chain Stay Yoke, you will need to use the C/S Yoke Support (O). Orient the tools as shown in Fig. 8.



- To press fresh DU Bushings into the dropout pivots (Bikes with aluminum rear triangles only) orient the tools as seen in Fig. 9. The DU Press (M) should center itself inside the DU Bushing. Tighten the bolt until the Flange on the DU Press touches the dropout. Repeat for both left and right dropouts.



- To press fresh DU Bushings into the Equilink, orient the tools as seen in Fig. 10. The EQ DU Press (N) should center itself inside the DU Bushing. Tighten the bolt until the Flange on the EQ DU Press touches the Equilink. The tool is designed to set the DU Bushings to the correct depth inside the Equilink. Repeat for all 4 Equilink DU Bushings.

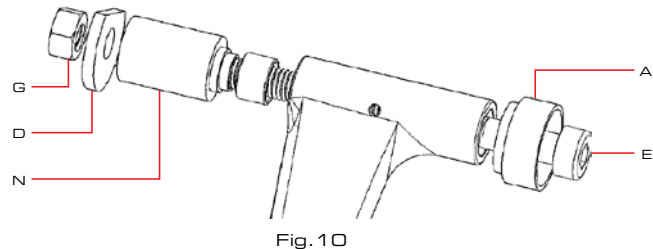

- After making sure that the bearing bolt/dust shield assemblies are cleaned of any contaminants, discard any damaged bearing bolts. You are now ready to re-assemble the frame.

## Frame Reassembly:

(Note: use Loctite 242 on all threads when reassembling)

- Take the rebuilt lower link along with the stainless steel spacer washers (placed on the inside between the bearing and the frame) and slide the link into place (some force may be required). Then reinstall the bearing bolt/dust shield assembly, tightening it to the torque specified on the dust shields.
- Attach the rebuilt upper link plates to the frame, making sure the stainless steel spacer washers are in place (placed on the inside between the bearing and the frame) and the link spacer is in place. Again torque the bearing bolt/dust shield assembly to the torque specified on the dust shields.
- Install the Equilink. The link is not symmetrical so it can't be installed in the wrong direction. Slide the ends of the link, along with the press in polymer washers, into the lower link and then between the shock links. Insert the Equilink Axles, the shorter one goes on the bottom, then insert the fixing bolts. If needed, there are "key" holes that can be aligned to help hold the Axle from spinning while tightening the fixing bolts. See Fig. 11. Tighten to the torque indicated on the link.

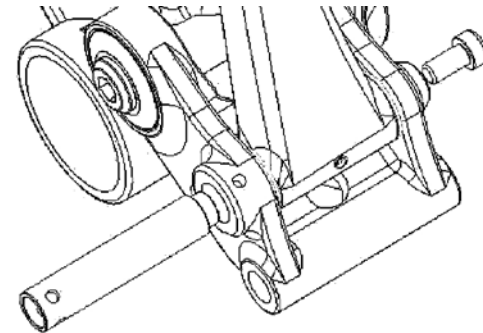

- Attach the chain stays to the lower link. With the stainless steel spacer washers in place tighten the bearing bolt/dust shield assemblies to the torque indicated on the dust shields.
- Attach the seat stays to the upper link. The links may need to be rotated up and down to position the link bolt holes in the correct position. Again, with the stainless steel spacer washers in place tighten the bearing bolt/dust shield assemblies to the torque indicated on the dust shields.

6. Reconnect the dropout pivots (aluminum rear end bikes only). Place an Acetyl Thrust Washer (FLAT w/ 13mm ID) in between the Seat Stay ends and the Dropouts on the Chain Stay. Slip the Dropout Axles through the DU Bushing at the end of the Seat Stay and through the Acetyl Thrust Washer, into the pocket in the dropout. Install the M6 x 20mm long Bolts through the axles and into the press-in axle nuts. Tighten to the torque specified on the frame, or 12Nm.
7. Re-install the shock, remembering that the upper and lower bolts may be different lengths. Once the bolts are assembled in their proper locations they will need to be tightened to the torque specified on the shock link.
8. Once complete, re-inflate the shock to your preferred pressure and/or recommended sag (see Section 3 of this manual for proper sag settings).
9. Pack the barrel of the Equilink with grease using a needle nose grease gun. The grease fittings on the backs of the Equilink allow a quick and easy service interface for the user to maintain the pivots of the Equilink.
10. Reinstall any parts you removed initially to access your suspension components.
11. Go Ride...
12. All pivot and mounting bolts should be re-checked for correct tightness/torque after the first ride and periodically ever few rides after that.

Reference these numbers to your bike's Series Parts List on the following pages.

Note: Carbon Rear Assemblies will not include part numbers 22 - 27.

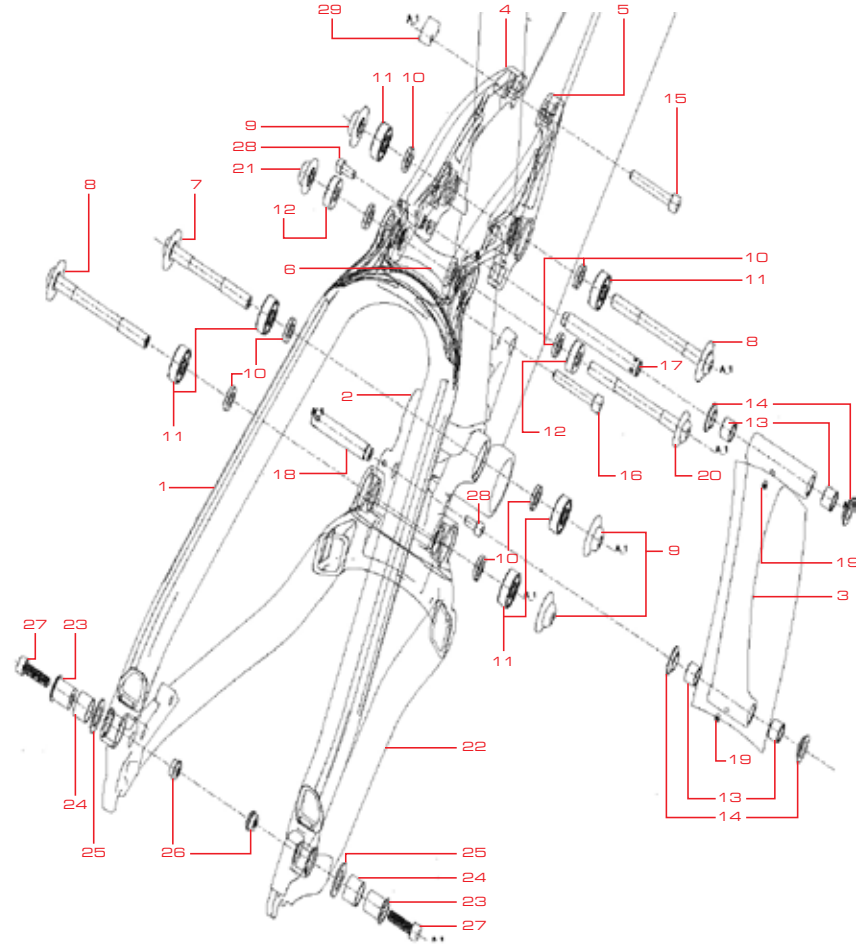

## 5. Equilink Parts Lists:

Virtue Full Carbon and Alloy/Carbon Series Parts Illustration

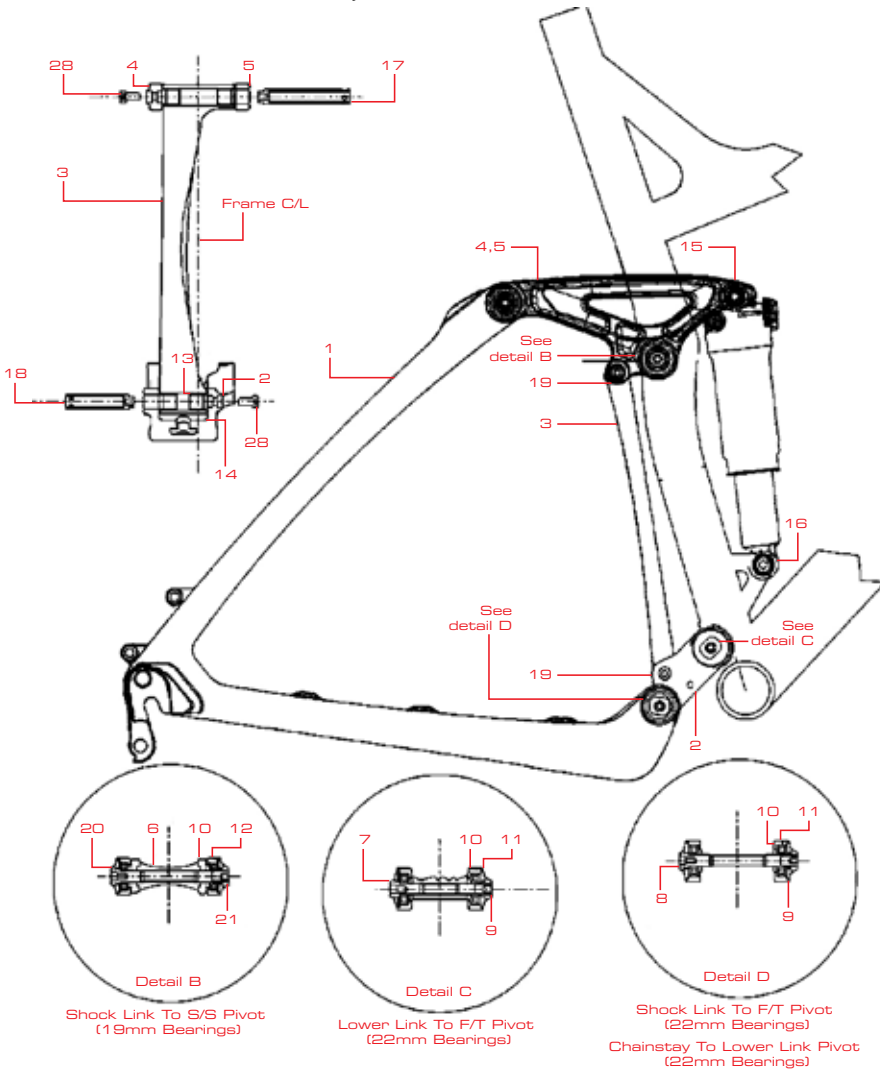

## Virtue Alloy/Carbon Series Parts List:

	QTY / Bike	
1.	Virtue Carbon Seat stay Assembly	1
2.	Chainstay Link	1
3.	Virtue Equilink	1
4.	Virtue Shock Link (Left)	1
5.	Virtue Shock Link (Right)	1
6.	Shock Link (Left)	1
7.	Pivot Nut Assembly (66.0mm lg.) w/22mm Cap	1
8.	Pivot Nut Assembly (78.0mm lg.) w/22mm Cap	2
9.	Pivot Nut Assembly w/22mm Cap	3
10.	Bearing Spacer 2.5mm	8
11.	Bearing 22x8x7 608 2RS Max Fill	6
12.	Bearing 19x8x6 698 2RS Max Fill	2
13.	DU Bushing 1008	4
14.	Acetyl Thrust Washer, Flanged, 10mm ID	4
15.	Bolt SHCS M6 x 1.0 x 35.0mm Long, Plated	1
16.	Bolt SHCS M6 x 1.0 x 40.0mm Long, Plated	1
17.	Upper Equilink Axle (Longer)	1
18.	Lower Equilink Axle (Shorter)	1
19.	Grease Port Filling, Allomite #1877	2
20.	Pivot Bolt Assembly (78. mm lg.) w/19	1
21.	Pivot Nut Assembly w/19mm Cap	1
28.	M5 X 0.8mm, 10mm Lg., SHCS, Plated	2
29.	Virtue Travel Chip	1

Virtue with Carbon Front Triangles use 2 x 40mm LG. Shock Bolts

Virtue Alloy/Alloy Series Parts Illustration.

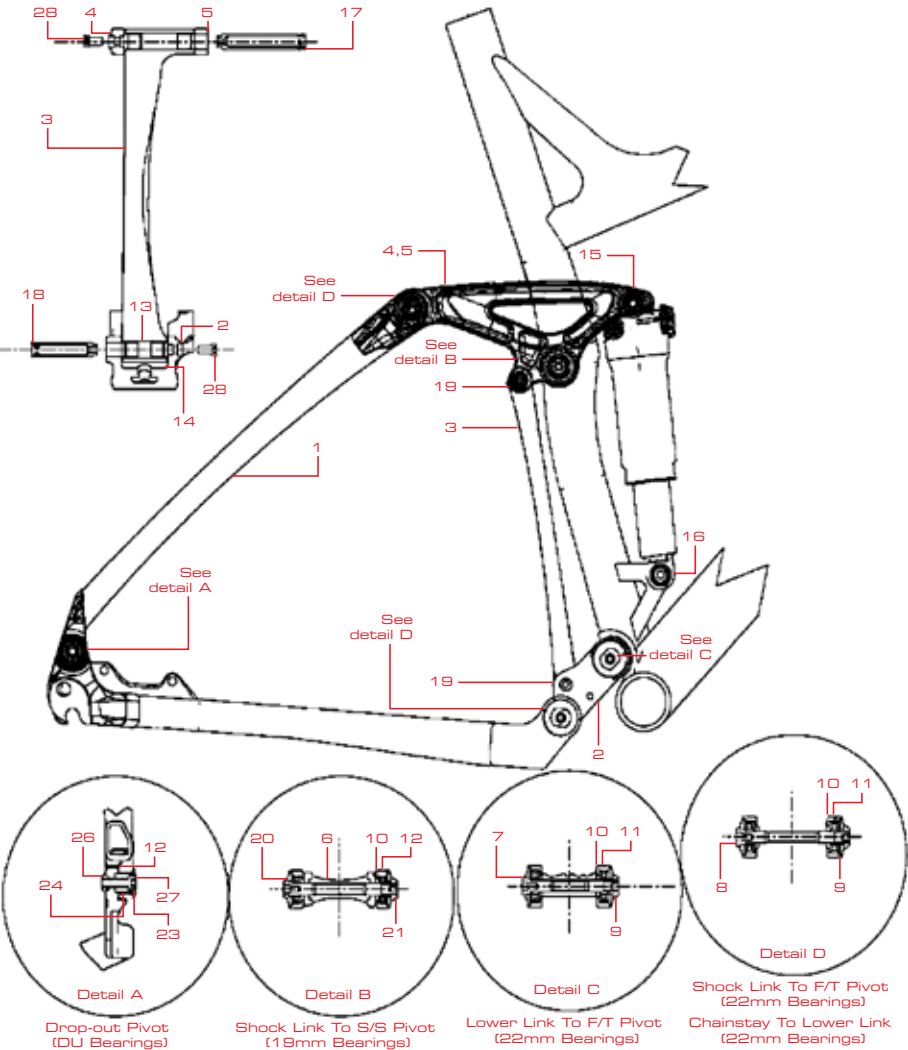

## Virtue Alloy/Alloy Series Parts List:

	QTY / Bike
1. Virtue Aluminum Seat stay Assembly	1
2. Chainstay Link	1
3. Virtue Equilink	1
4. Virtue Shock Link (Left)	1
5. Virtue Shock Link (Right)	1
6. Shock Link (Left)	1
7. Pivot Nut Assembly (66.0mm lg.) w/22mm Cap	1
8. Pivot Nut Assembly (78.0mm lg.) w/22mm Cap	2
9. Pivot Nut Assembly w/22mm Cap	3
10. Bearing Spacer 2.5mm	8
11. Bearing 22x8x7 608 2RS Max Fill	6
12. Bearing 19x8x6 698 2RS Max Fill	2
13. DU Bushing 1008	4
14. Acetyl Thrust Washer, Flanged, 10mm ID	4
15. Bolt SHCS M6 x 1.0 x 35.0mm Long, Plated	1
16. Bolt SHCS M6 x 1.0 x 40.0mm Long, Plated	1
17. Upper Equilink Axle (Longer)	1
18. Lower Equilink Axle (Shorter)	1
19. Grease Port Filling, Allomite #1877	2
20. Pivot Bolt Assembly (78.mm lg.) w/19	1
21. Pivot Nut Assembly w/19mm Cap	1
22. Virtue Alloy Chainstay Assembly	1
23. Dropout Pivot Axle	2
24. DU Bushing 1310	2
25. Acetyl Thrust Washer, Flat, 13mm ID	2
26. Dropout Pivot Axle Nut	2
27. M6 X 1.0mm SHCS X 20.0mm LG., Plated	2
28. M5 X 0.8mm, 10mm Lg., SHCS, Plated	2
29. Virtue Travel Chip	1

## 6. Equilink Carbon Care Guide:

1. This guide contains **important** information. Please read carefully and store in a safe place.

**Warning!** Failure to follow these instructions may result in a catastrophic failure of the frame and/or its components while riding, which may result in serious personal injury or death.

Congratulations! The Felt Suspension frame you have chosen is among the finest products available in cycling. The Carbon fiber that is used in the rear triangle of some Equilink frames is a very special material that requires particular care during assembly, storage and riding. This short reference guide contains instructions and warnings specific to Felt Suspension frames that use these Carbon rear triangles.

Unlike metal parts, carbon composite parts that have been damaged may not bend, bulge or deform; a damaged part may appear to be normal to a cursory glance. After any high force load, like a crash, or other impact to your bicycle, thoroughly inspect all the parts of your bike, and use the following procedures to inspect carbon composite parts.

- Check for scratches, gouges, or other surface problems.
- Check the part for loss of rigidity.
- Check the part for delamination.

If you are the slightest bit unsure... If you have any doubts about the integrity of any part of your Felt Bicycle, do not ride the bicycle and contact either Felt Bicycles directly or your local Felt Bicycles authorized dealer for more information or answers to your questions.

Be very careful when handling carbon fiber parts that are suspected of damage. When a composite part is damaged, there is a possibility that individual fibers may be exposed. Carbon fibers are thinner than a human hair, but quite stiff. If the point of one of these fibers is pressed against your skin, it could pierce your skin like a needle.

**Warning!** A damaged carbon fiber part can fail suddenly, causing serious injury or death. Inspect a carbon fiber bicycle, or parts, for damage frequently. If you suspect a carbon fiber part is damaged, replace the part before riding or take the bike to your dealer for service.

**Warning!** Do not clamp to, modify or otherwise alter the frames Carbon Fiber rear triangle. As well as voiding your warranty it may impair the structural integrity of the frame. Failure to follow this warning may result in serious personal injury or death.

Please visit [feltbicycles.com](http://feltbicycles.com) for the latest technical information on our proprietary technology.

The logo for Felt Bicycles, featuring the word "FELT" in a bold, italicized, sans-serif font with a thick outline. The letters are slanted upwards from left to right. The logo is positioned in the bottom right corner of the page, above a red diagonal line that runs from the bottom left towards the top right.

**FELT**  
Virtue Suspension Manual



Felt Bicycles 12 Chrysler Irvine, California 92618, USA

[feltbicycles.com](http://feltbicycles.com)