



FEELT

Bayonet 3 Manual

Bayonet 2 Parts List:

1. M6 X 30mm Bolts
2. Stem Extension
3. M6 X 30mm Bolt (Knuckle)
4. Knuckle Side Cap
5. Set Screw
6. Stem Base/Top Crown
7. Splined Shaft/Knuckle
8. M6 X 18mm Bolt
9. Steerer Nut
10. Steer Lock Screw
11. Split Top Bearing Race
12. Headset Bearings
13. Crown Race
14. Steerer Shaft

Bayonet 2

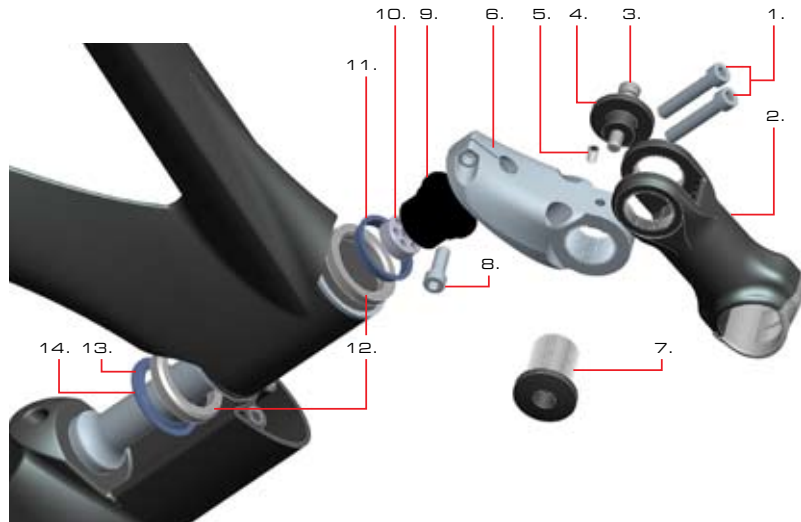

Bayonet 3 Parts List:

1. M6 X 40mm Bolts
2. Stem Extension
3. M6 X 30mm Bolt (Knuckle)
4. Knuckle Side Cap
5. Set Screw
6. Stem Base/Top Crown
7. Splined Shaft/Knuckle
8. M6 X 18mm Bolt
9. Steerer Nut
10. Steer Lock Screw
11. Custom Bayonet 3 Headset Bearings
12. Steerer Shaft

Bayonet 3

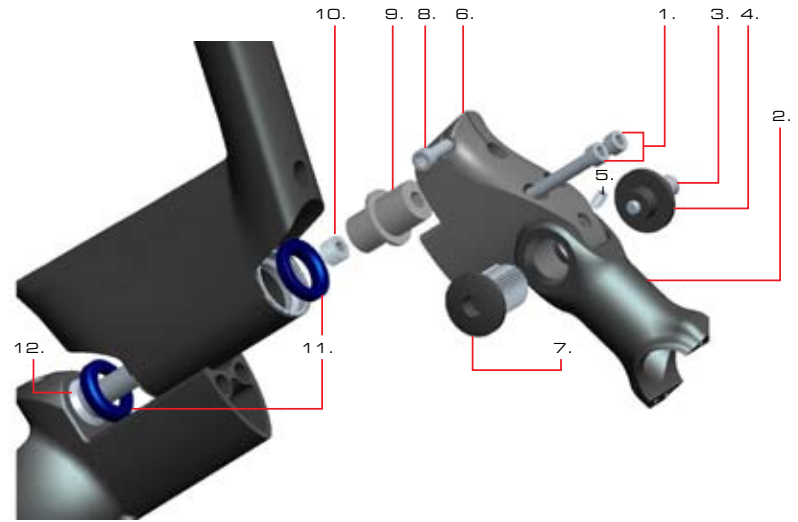

NOTE: Felt recommends that any maintenance needed to the Felt Bayonet Steering System is done by a certified mechanic at a Felt Authorized Dealer. However, a video and assembly instructions are included with every Felt bicycle or frame equipped with a Felt Bayonet Steering System. These are also available on the Felt website: feltbicycles.com

Step One:

Install the Lower Bearing Race on the fork's Steerer Shaft like you would on any standard fork. (See Fig.1A)

For Bayonet 3, the crown race is integrated into the Steerer Shaft. (See Fig.1B)



Fig.1A



Fig.1B

Step Two: (See Fig.2)

Assemble the Steerer Shaft Nut and Steerer Lock Screw.

- Be sure to use an anti-seize compound on the aluminum threads to prevent seizing and galling.
- Using the 6mm Allen key, thread the Steerer Lock Screw into the Shaft Nut in until it hits top of the Shaft Nut. Do not tighten the Steerer Screw down. You are just moving it out of the way for installation later.

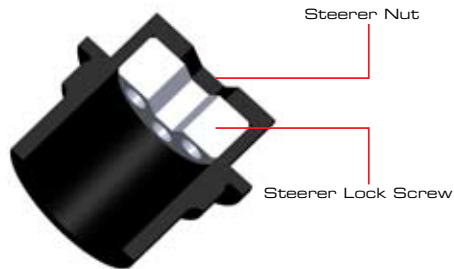

Fig.2

Step Three:

Slide the Bearing Top Race on to the Steerer Shaft Nut. (See Fig.3A)

For Bayonet 3, the Top Race is integrated into the Steerer Shaft Nut. (See Fig.3B)



Fig.3A

Fig.3B

Step Four: (See Fig.4)

Insert the bearings into the frame making sure that the chamfered (angled) side of the bearing is inserted first.

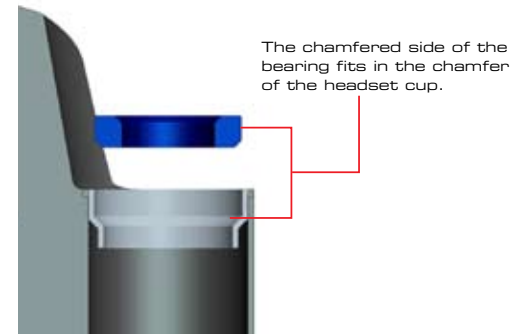

Fig.4

Step Five:

Insert the appropriate Bayonet Fork into the frame.

Step Six: (See Fig.6)

Thread the Steerer Shaft Nut onto the Steerer Shaft.

- Be sure to use an Anti-Seize Compound on the aluminum threads to prevent seizing and galling.
- Use an 8mm Allen key to thread the Shaft Nut onto the Steerer Shaft.

This will determine the headset tension. Adjust it just like a standard threadless headset. Do not over tighten.

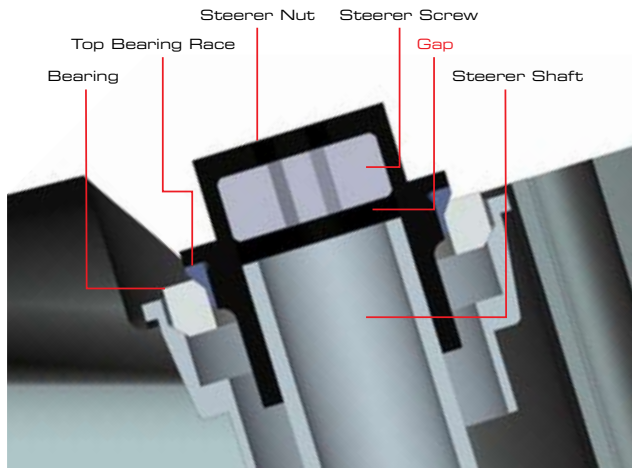

Fig.6

Step Seven:

Adjust the Steerer Lock Screw to hold the headset adjustment.

- Using a 6mm Allen, insert the Allen key through the opening in the Steerer Nut into the Steerer Lock Screw.
- Turn the Steerer Lock Screw clockwise until it contacts the Steerer Shaft. The Steerer Lock Screw locks the headset adjustment.
- Tighten this to 12Nm with a torque wrench. (See Fig.7)

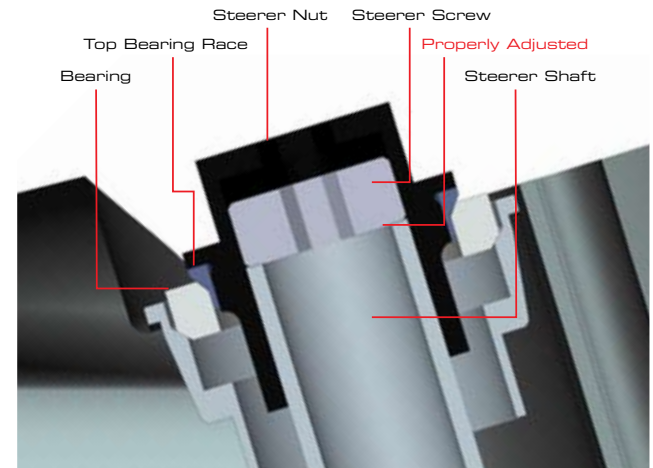

Fig.7

Step Eight: (See Fig.8)

Slip the Stem Extension over the Stem Base.

- Then insert the Splined Shaft/Knuckle into the Stem Extension being sure to align the slot of the Splined Shaft with the slot in the Stem Base. This assures a smooth fit and that the Set Screw (which will be installed in step # 11) will seat properly. This will set the angular position of the stem, so double check the Stem Extension's position before installing the Splined Shaft.

Be sure to align the flats when inserting the splined shaft/knuckle.

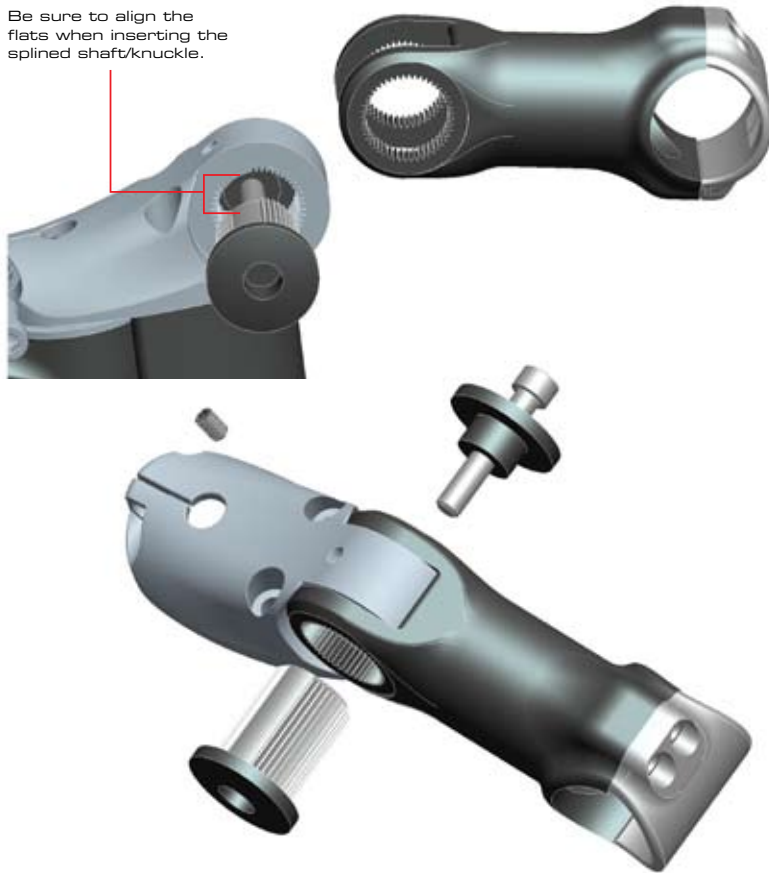

Fig.8

Step Nine:

Install the Bayonet Stem.

- Install the Bayonet Stem over the Steerer Shaft Nut.
- Insert the M6 x 30mm (Bayonet 2) or M6 x 40mm (Bayonet 3) bolts through each hole in the stem, through to the threads in the Bayonet Fork.
- Tighten the bolts to 12Nm with a torque wrench. (See Fig.9)

Step Ten:

Tighten the M6 x 18mm pinch bolt in the Bayonet Stem. (See Fig.9)

- Tighten the bolt to 12Nm with a torque wrench.

Step Eleven:

Insert the Set Screw into the back of the Bayonet Stem. This will lock the stem angle adjustment.



Fig.9

And You're Done:

Please remember to check all bolts and hardware regularly for correct tension to ensure optimum performance and function.

Please visit feltbicycles.com for the latest technical information on our proprietary technology.



Felt Bicycles 12 Chrysler Irvine, California 92618, USA

feltbicycles.com